



HORIZONTAL SCREENS

5x16 / 6x16 / 6x20 / 7x20

- Easily converts to wet screen applications.
- Adjusts to fit fine or coarse screening.
- Fully contained oil lubrication system.
- Interchangeable decks for different screening needs.

CLEMRO

© 05.2015 / Clemro Western Ltd.

P/1

DIMENSIONS

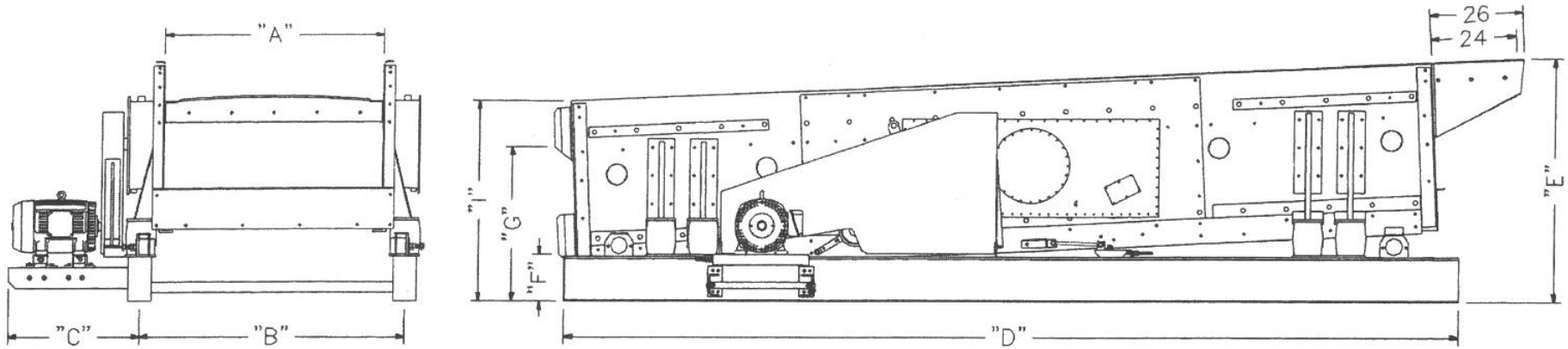

2 DECK SCREENS

Screen Size / Model	1800 RPM HP (kw)	Basket Weight lbs (kg)	A inch (mm)	B inch (mm)	C inch (mm)	D inch (mm)	E inch (mm)	F inch (mm)	G inch (mm)	I inch (mm)
5162-32	25 (18)	12,500 (5,670)	61.5" (5,562)	74.25" (5,562)	37.0" (940)	201.5" (5,562)	66.125" (1,680)	13.0" (330)	43.0" (1,092)	56.25" (1,429)
6162-32	30 (22)	15,100 (6,850)	76.0" (1,930)	88.75" (2,254)	37.0" (940)	225.5" (5,728)	66.125" (1,680)	13.0" (330)	43.0" (1,092)	56.25" (1,429)
6202-32	40 (29)	19,100 (8,664)	76.0" (1,930)	88.75" (2,254)	37.0" (940)	249.5" (6,637)	68.375" (1,737)	13.0" (330)	43.0" (1,092)	56.25" (1,429)
7202-38	50 (37)	22,500 (10,205)	88.0" (2,235)	101.0" (2,565)	39.0" (990)	249.5" (6,337)	74.75" (1,898)	15.75" (400)	50.0" (1,270)	62.5" (1,587)

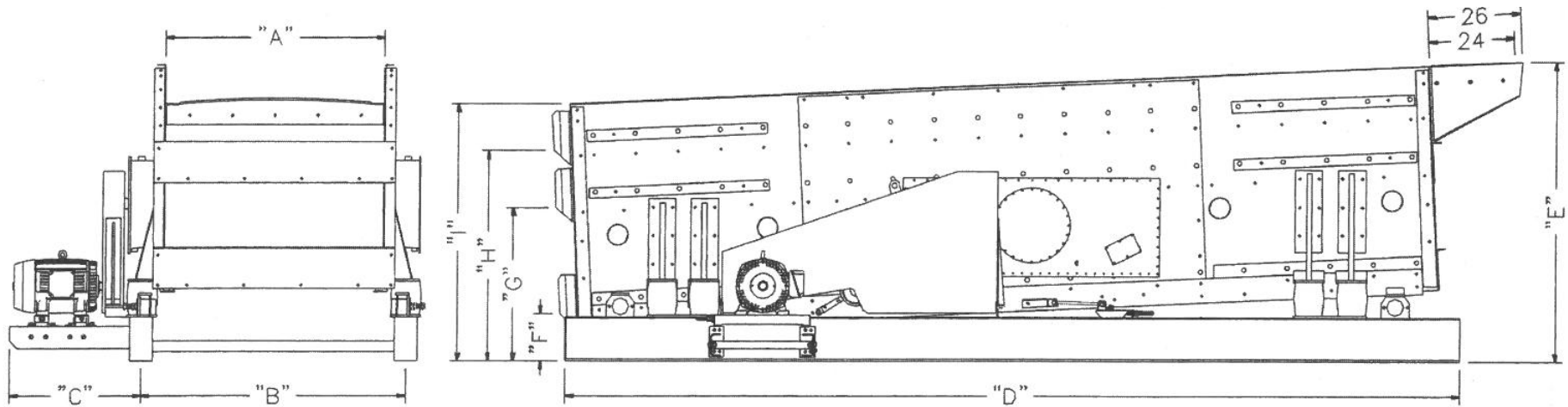

3 DECK SCREENS

Screen Size / Model ft (m)	1800 RPM HP (kw)	Basket Weight lbs (kg)	A inch (mm)	B inch (mm)	C inch (mm)	D inch (mm)	E inch (mm)	F inch (mm)	G inch (mm)	H inch (mm)	I inch (mm)
5163-32	25 (18)	15,400 (6,985)	61.5" (5,562)	74.25" (1,886)	37.0" (940)	201.5" (5,118)	82.0" (2,082)	13.0" (330)	43.0" (1,092)	59.0" (1,499)	72.0" (1,828)
6163-32	30 (22)	19,200 (8,710)	76.0" (1,930)	88.75" (2,254)	37.0" (940)	201.5" (5,118)	82.0" (2,082)	13.0" (330)	43.0" (1,092)	59.0" (1,499)	72.0" (1,828)
6203-32	40 (29)	22,800 (10,340)	76.0" (1,930)	88.75" (2,254)	37.0" (940)	249.5" (6,637)	84.4" (2,142)	13.0" (330)	43.0" (1,092)	59.0" (1,499)	72.0" (1,828)
7203-38	50 (37)	26,400 (11,974)	88.0" (2,235)	101.0" (2,565)	39.0" (990)	249.5" (6,337)	90.0" (2,286)	13.0" (330)	47.0" (1,193)	65.0" (1,651)	78.0" (1,981)

SPECIFICATIONS

FEATURES

- Easily converts to wet screen applications
- Quickly adjust to fit fine or coarse screening
- Fully contained oil lubrication system
- Includes belt guards for safe operation
- Interchangeable decks for different screening needs
- Utilizes keyless hold-fast hub locking assembly system
- Superior load carrying double-roll spherical bearings
- Balanced to accept various length discharge lips
- High strength longer lasting drawplates
- Rubber spring reduced basket stress
- Low overall screen height for portability
- No weld-on sidewall washers
- More favorable shaft assembly location
- Improved double seal drive shaft oil sealing
- Improved 3C banded belt drive

OPTIONS

- 1,800 or 1,200 rpm TEFC electric motor
- End-tension bottom deck
- Cast urethane decks
- Wide screen cloth
- Left-handed or right-handed drive
- Spray system
- Rubber spray hole covers
- Special-length discharge lips
- Divided decks

DECK SCREENS	
	Dimensions Inch (mm)
Maximum Stroke (Stroke can be reduced by removing weight plugs.)	0.75" (19mm)
Recommended Speed Range (rpm)	675-875
Maximum Feed Size	10.0" (254mm)
Maximum Top Deck Opening	5.0" (127mm)
Maximum Drop of Feed	18.0" (457mm)
Cloth Support Bar Thickness	0.375" (10mm)
Side Plate Thickness	0.25" (6mm)
Reinforcing Plate	0.125" (3mm)
Feed Box Liners (AR Plate)	0.25" (6mm)
Bearing Size	32.0" (160mm)

PHOTO GALLERY

